

XMF 1.7 CARBON

FANTIC



FANTIC

XMF 1.7 CARBON



Color: Negro



E-MTB All Mountain de Fantic, ¡la palabra clave es versatilidad. Diseñado para ofrecer un excelente equilibrio ser entre el rendimiento cuesta abajo y el pedal cuesta arriba. Diseñado y desarrollado por Fantic para aquellos que buscan un alto rendimiento, bicicleta polivalente, de alto rendimiento, y apto para todo tipo de senderos y caminos.

Especificaciones Técnicas



Carbón, tallas: S - M - L



Sram SX, 12V, 11-50

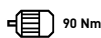

Brose S-Mag 36, Torque: 90 Nm



Sram CODE R 4 Piston disc brake



Fantic, Lithium Ion, 36 Volt, 720Wh



Fulcrum E-Fire 700



RockShox DOMAIN R 170mm



Vittoria E-Martello



RockShox SuperDeluxe Select+



Selle Italia X-Bow Superflow

PRODUCTO
ACTUALIZADO

410%

ASISTENCIA

DROPPER
SEATPOSTHEAD
LOOK

34x11x50

XMF 1.7 CARBON

FANTIC

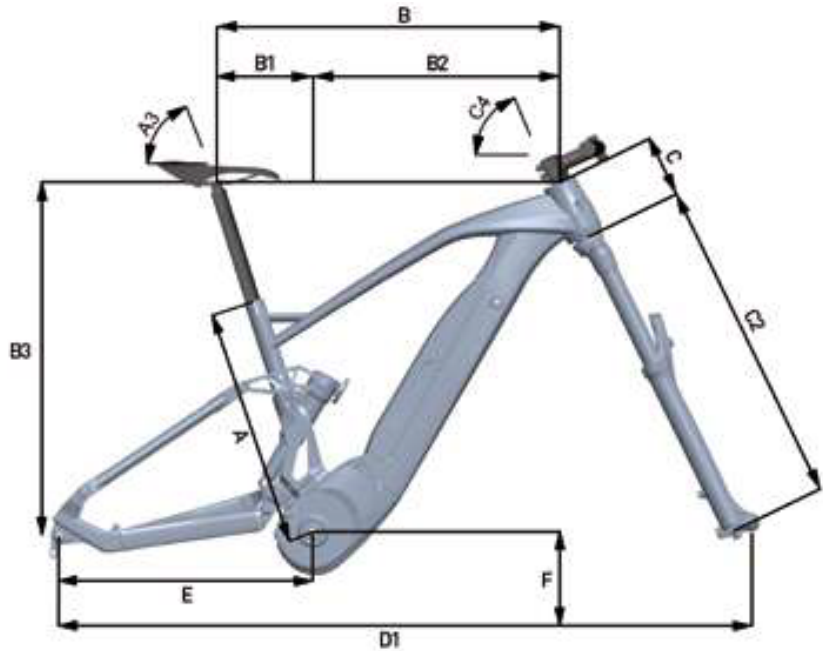

Motor	Brose S-Mag 36 Volt, Torque: 90 Nm
Bateria	Fantic, Lithium Ion, 36 Volt, 720Wh
Pantalla	Brose-Marquardt Pantalla multifuncional y unidad de selección de asistencia de empuje
Cuadro	Carbón, tallas: S - M - L
Suspensión	RockShox DOMAIN R 170mm
Amortiguador	RockShox SuperDeluxe Select+
Plato	Sram 34t
Biela	FSA: 165 mm
Cambio trasero	Sram GX
Palanca de cambios	Sram NX Eagle
Cassette	Sram SX, 12V, 11-50
Cadena	Sram SX
Freno delantero	Sram CODE R 4 Piston disc brake
Freno trasero	Sram CODE R 4 Piston disc brake
Disco delantero	Braking S3 Battfly, 203mm – 6 pernos
Disco trasero	Braking S3 Battfly, 203mm – 6 pernos
Llanta delantera	E-Martello 29"x 2.35
Llanta trasera	E-Martello 27,5"x 2.6
Ruedas	Fulcrum E-Fire 700
Manillar	FSA Grid - 800mm - Ø35 - Rise 15mm
Poste de manubrio	FSA Grid-50mm- Ø35 - Rise +6°
Tija de sillín	Switch SW Ø 30.9
Asiento	Selle Italia X Bow Superflow

Tallas	S	M	L
A	390	430	469
A3	73	73	73
B	586	596	628
B1	161	162	166
B2	425	454	480
B3	617,8	622,0	633,7
C	105	110	120
C2	581	581	581
C4	65	65	65,5
D1	1241	1245	1270,5
E	459	459	459
F	363,5	363,5	363,5

[*] FANTIC MOTOR se reserva el derecho de modificar las características técnicas sin previo aviso. Todas las imágenes se incluyen con fines ilustrativos. Los productos están sujetos a cambios.