

XTF 1.5 SPORT

FANTIC



FANTIC

XTF 1.5 SPORT



Color: Amarillo



Color: Plata



El cuadro de aluminio hidroformado proporciona rigidez y una excelente capacidad de conducción con una geometría que da lo mejor de sí en cada curva, cada salto y cada bajada. La XTF 1.5 es la bicicleta de trail con mejor relación calidad-precio.

Especificaciones Técnicas



Aluminio, Tallas: S - M - L



Sram NX

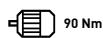

Brose S-Alu, Torque 90 Nm



Freno de disco Sram GUIDE T 4 Pistones



Fantic, 36 voltios, 630 Wh



Rodi TRYP30



RockShox 35 GOLD RL 150mm



Pirelli SCORPION Trail



RockShox Deluxe Select+

Selle Italia Model X
Comfort Superflow 145PRODUCTO
ACTUALIZADO

410%

ASISTENCIA

DROPPER
SEATPOSTHEAD
LOOK

34x11x50

XTF 1.5 SPORT

FANTIC

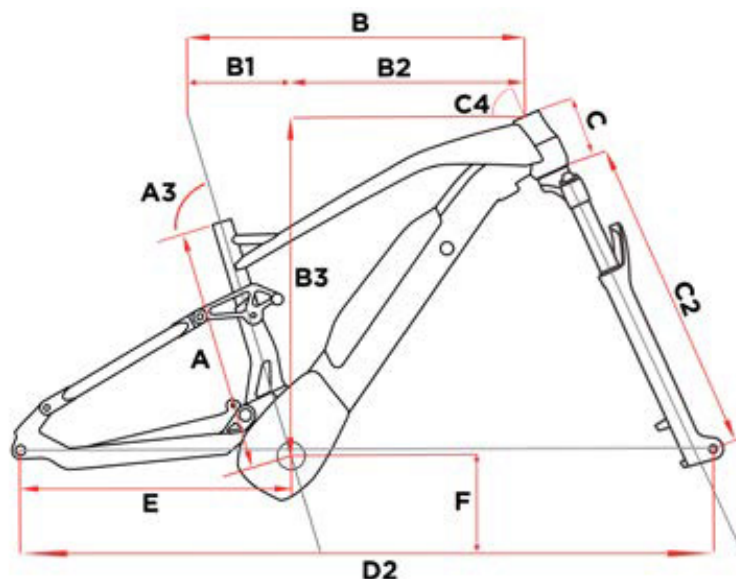

Motor	Brose S-Alu, Torque 90 Nm
Batería	Fantic, 36 voltios, 630 Wh
Pantalla	Brose-All Round
Cuadro	Aluminio, Tallas: S - M - L
Suspensión	RockShox 35 Gold RL 150 mm
Amortiguador	RockShox Deluxe Select+
Plato	Sram 34t
Biela	Miranda
Cambio trasero	Sram NX
Palanca de cambios	Sram NX Eagle
Cassette	Sram SX, 12V, 11-50
Cadena	Sram SX
Freno delantero	Freno de disco Sram GUIDE T 4 Pistones
Freno trasero	Freno de disco Sram GUIDE T 4 Pistones
Disco delantero	SramCenterLine, 200mm - 6 pernos
Disco trasero	SramCenterLine, 180mm - 6 pernos
Llanta delantera	Pirelli SCORPION Trail -S- 29"x 2.4
Llanta trasera	Pirelli SCORPION Trail -R- 29"x 2.4
Ruedas	Rodi TRYP30
Manillar	Promax ø31,8 760mm Elevación 20mm
Poste de manubrio	Promax 60MM ±6° ø31,8
Tija de sillín	Promax teles. SP -2038 Ø 30.9, S 80mm / M-L 100mm
Asiento	Selle Italia MODEL-X Comfort Superflow 145

Tallas	S	M	L
A	390	430	490
A3	73	73	73
B	573	602	627
B1	166	169	174
B2	407	433	453
B3	615,8	625,0	641,5
C	105	115	130
C2	567	567	567
C4	66	66	66,5
D1	1193	1224	1244
E	472	472	472
F	358	358	358

[*] FANTIC MOTOR se reserva el derecho de modificar las características técnicas sin previo aviso. Todas las imágenes se incluyen con fines ilustrativos. Los productos están sujetos a cambios.