

XXF 2.0 FACTORY

FANTIC



FANTIC

XXF 2.0 FACTORY



Color: Blanco



Color: Verde Militar



Los componentes de alta gama brindan agilidad y manejo en saltos y curvas extremos, ofreciendo control y estabilidad óptimos a altas velocidades. Más control, más velocidad, más autonomía, más potencia, más kilómetros por recorrido y aún más diversión.

Especificaciones Técnicas



Aluminio, Tallas: S - M - L



Sram GX Eagle

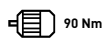

Brose S-Mag 36, Torque 90 Nm



Freno de disco IN.CA.S



Fantic, 36 voltios, 720 Wh



Mavic E-Deemax 29"-27.5"



Ohlins DH 38 200mm

Vittoria E-Mazza
Vittoria E-Martello

Ohlins TTX 22M



Selle Italia Novus Boost X Cross Superflow

PRODUCTO
ACTUALIZADO

410%

ASISTENCIA

DROPPER
SEATPOSTHEAD
LOOK

34x11x50

XXF 2.0 FACTORY

FANTIC

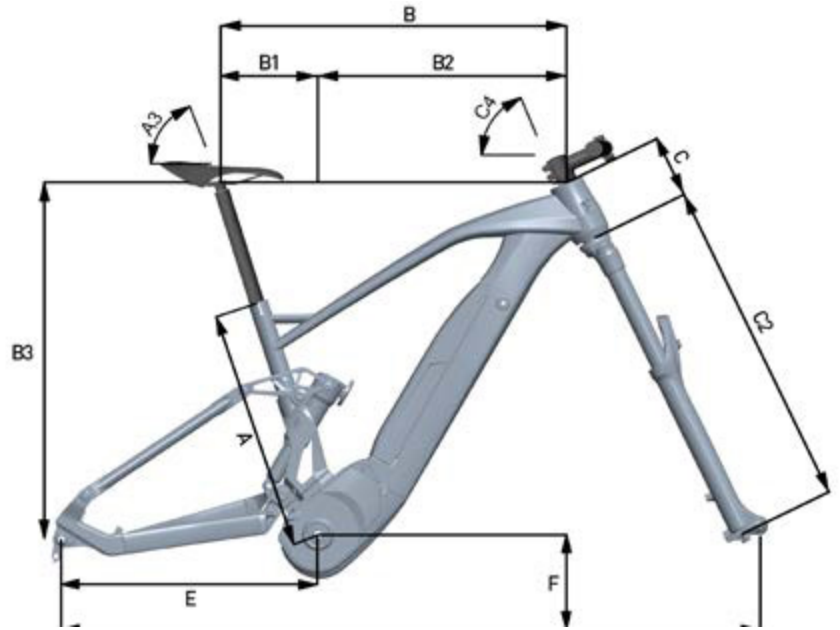

Motor	Brose S-Mag 36, Torque 90 Nm
Bateria	Fantic, 36 voltios, 720 Wh
Pantalla	Brose remote
Cuadro	Aluminio, Tallas: S - M - L
Suspensión	Ohlins DH 38 200mm
Amortiguador	Ohlins TTX 22M
Plato	Sram 34t
Biela	FSA
Cambio trasero	Sram GX
Palanca de cambios	Sram GX Eagle
Cassette	SunRace SiverRed, 12V, 11-51
Cadena	Sram NX
Freno delantero	Freno de disco IN.CA.S
Freno trasero	Freno de disco IN.CA.S
Disco delantero	S3 Battfly, 220 mm - 6 pernos
Disco trasero	S3 Battfly, 203 mm - 6 pernos
Llanta delantera	Vittoria E-MAZZA 29"x 2.6
Llanta trasera	Vittoria E-MARTELLLO 27,5"x 2.8
Ruedas	MAVIC E-DEEMAX 29"- 27.5"
Manillar	Fantic Racing-800mm- Ø35 - Elevación 30mm -Arena
Poste de manubrio	Fantic Racing Diretto -35mm- Ø35
Tija de sillín	Crankbrothers HIGHLIGHT7 Ø 30.9
Asiento	Selle Italia Novus Boost X Cross Superflow

Tallas	S	M	L
A	390	430	469
A3	73	73	73
B	586	596	628
B1	161	162	166
B2	425	454	480
B3	617,8	622,0	633,7
C	105	110	120
C2	581	581	581
C4	65	65	65,5
D1	1241	1245	1270,5
E	459	459	459
F	363,5	363,5	363,5

(*) FANTIC MOTOR se reserva el derecho de modificar las características técnicas sin previo aviso. Todas las imágenes se incluyen con fines ilustrativos. Los productos están sujetos a cambios.